

L. BOLLMANN.

MACHINES FOR CUTTING SCREW-THREADS.

No. 191,826.

Patented June 12, 1877.

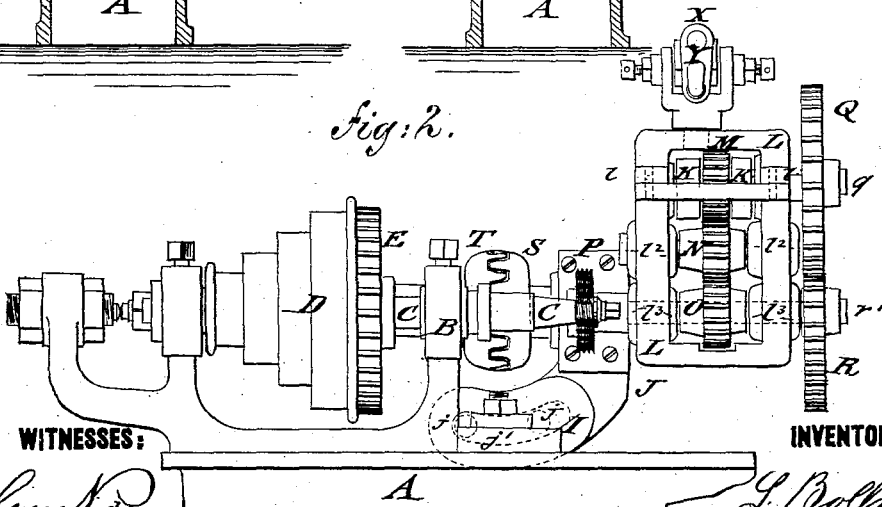
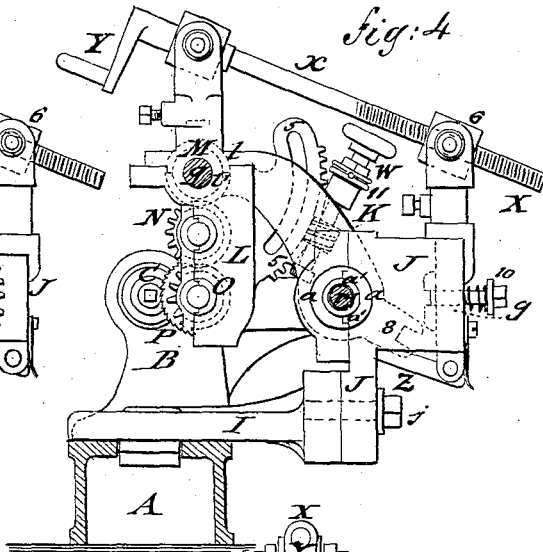
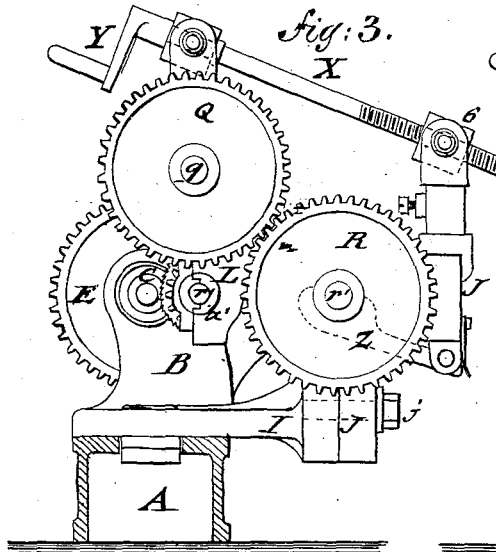
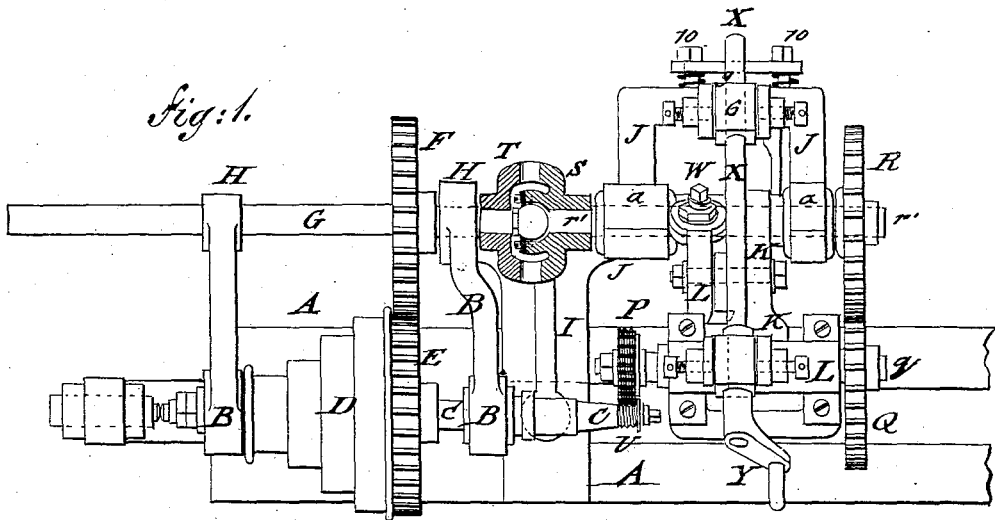

WITNESSES:

Chas. Nida
A. F. Terry

INVENTOR:

L. Bollmann
 BY *Munnif*
 Y.

L. BOLLMANN.

MACHINES FOR CUTTING SCREW-THREADS.

No. 191,826.

Patented June 12, 1877.

Fig: 5.

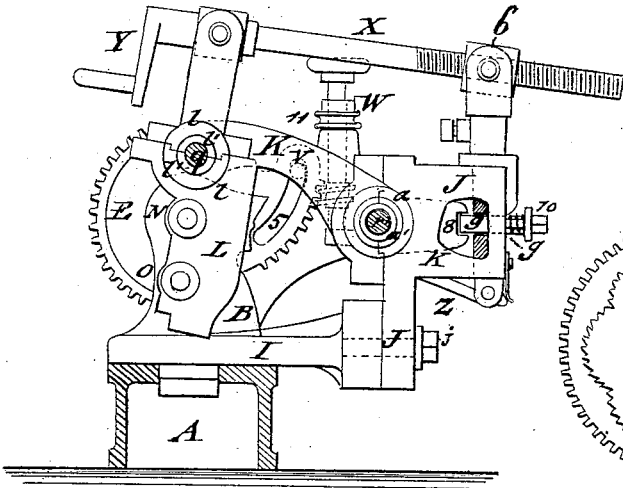

Fig: 6.

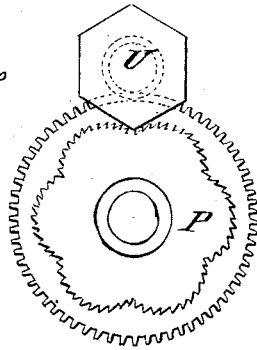

Fig: 7.

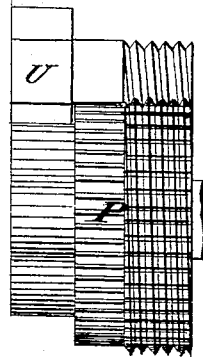

Fig: 8.

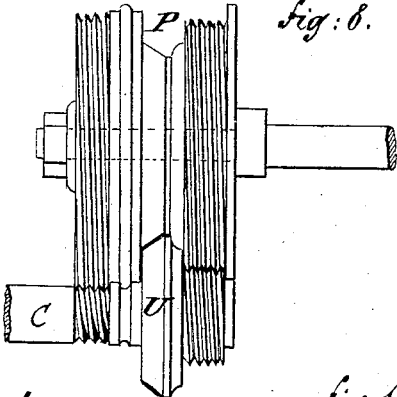

Fig: 9.

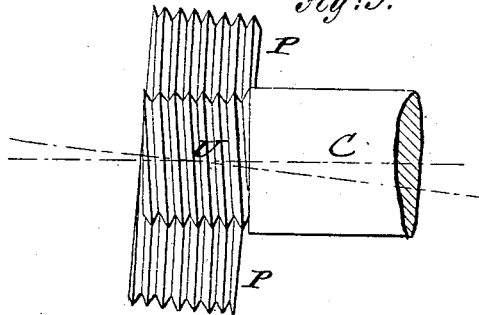

Fig: 10.

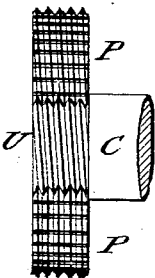

Fig: 11.

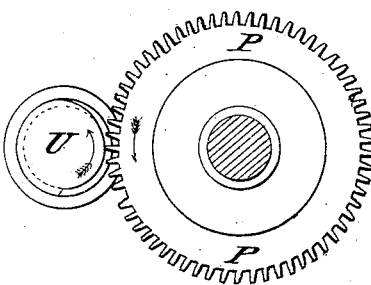

Fig: 12.

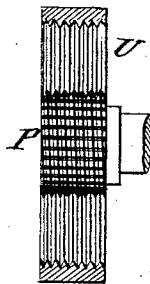
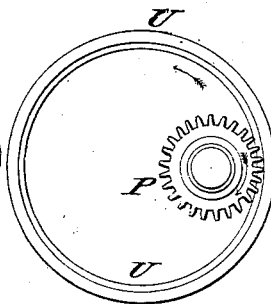

Fig: 13.



WITNESSES:

Chas. Nield
J. H. Scarborough

INVENTOR:

L. Bollmann
BY *Munnell*

ATTORNEYS.

UNITED STATES PATENT OFFICE.

LOUIS BOLLMANN, OF VIENNA, AUSTRIA.

IMPROVEMENT IN MACHINES FOR CUTTING SCREW-THREADS.

Specification forming part of Letters Patent No. **191,826**, dated June 12, 1877; application filed January 3, 1877.

To all whom it may concern:

Be it known that I, LOUIS BOLLMANN, of Vienna, in the Empire of Austria, have invented a new and Improved Machine for Cutting Screw-Threads and other regular and irregular forms, of which the following is a specification:

In the accompanying drawing, which illustrates my invention, Figure 1 represents a plan view of my improved machine for cutting screw-threads or other forms. (Shown as attached to a lathe.) Fig. 2 is a front elevation; Fig. 3, a side elevation; and Fig. 4, also a side view of the same, partly in section, with the cog-wheels removed to show the interior parts. Fig. 5 is a sectional side view of the machine as applied for cutting internal screw-threads. Figs. 6, 7, and 8, are, respectively, detail, end, and side views of cutter and work, showing application of machine to irregular circular forms. Fig. 9 illustrates the oblique position of the cutter to the work; and Figs. 10, 11, 12, and 13 are side and end views of cutter and work, illustrating, respectively, positions of the same for external or internal work.

Similar letters of reference indicate corresponding parts.

The invention relates to machinery for cutting screw-threads; and consists in certain improvements, which will first be described in connection with the drawing, and then pointed out in the claims.

In the drawings, the machine is represented as attached to a turning-lathe, the object to be cut being fastened to the lathe-spindle in any suitable manner, and in which A is the bed of the lathe; B, the spindle-head; C, the spindle, and D the belt-pulley.

To the spindle C is fastened the cog-wheel E, gearing into a similar cog-wheel, F, fastened to the shaft G, that turns in bearings of the arms H H of the spindle-head.

On the lathe-bed A is screwed the bed-plate I, which is shown in Figs. 1, 3, 4, and 5.

J is the support, fastened to the bed-plate I by means of two screws, *jj*. The upper part of support J is made of angular shape, and provided with bearings *a a*, in which the studs *a' a'* of the arm K turn, as shown in Fig. 4.

The upper end of arm K is formed like a

fork, and has two studs, *l l*, on which hangs, by proper bearings *l l*, the swinging frame L. These studs *l l* are hollow, so that the small shaft *g*, to which the cog-wheel M is fastened centrally to frame L, as shown in Figs. 2 and 4, can pass through them.

The frame L has further bearings, *l' l' l' l'*, in which turn two additional shafts, with cog-wheels N and O, of which N gears into M, and O into N, each of said three wheels having an equal number of teeth. To the shaft of the lowermost wheel, O, is fastened the cutter P.

The shaft *g* has fastened on its right-hand end a second large cog-wheel, Q, gearing into a like wheel, R, fastened to shaft *r'*, which turns in the hollow or tubular studs *a' a'* of the arm K, and which carries on its left end the clutch-wheel S, that gears with a second clutch-wheel, T, fastened on shaft G. These clutch-wheels are clearly shown in section in Fig. 1 and in side elevation in Fig. 2.

The shaft G is extended into a spherical cavity of the clutch-wheel S, and made ball-shaped at the end to form a universal joint, that connects the shafts G and *r'* in such a manner that they must both rotate together, while the shaft *r'* can be set into a more or less oblique position.

This is accomplished by the set screws *jj* passing through arc-shaped slots *j' j'*, which are concentric to the center of the spherical end of the shaft G. By loosening these screws the apparatus can be set obliquely to the bed-plate and lathe without getting the wheels S and T out of proper gear. The object of this oblique position will be explained hereafter.

The pendent frame L is formed with a slotted arc-shaped projection, 5, concentric to the axis of shaft *g*, and provided with teeth, into which a small screw-spindle, W, gears, that turns in suitable eyes or seats cast on arm K, as shown in Fig. 4. By turning this screw-spindle with its hand-wheel the frame L will swing on the studs *l l* of the arm K.

The screw V, (shown in Fig. 5,) which passes through a slot in the segmental part 5 of pendent frame L, fastens frame L to arm K, so that both are forming one piece after the cutter is properly adjusted.

In order to bring the cutter P in contact with the work U fastened to the lathe-spindle C, the arm K, and with it the frame L, is made to swing on the shaft r' by turning the screw-spindle X by its crank Y. This spindle turns in a universal joint connecting it to the frame L, while its nut 6 is part of another universal joint connected to support J.

These two universal joints allow the spindle and nut to adjust themselves to the required positions, as will be understood by reference to Figs. 3 and 4. By turning the spindle X in proper direction the arm K and frame L will be moved to bring the cutter P into contact with the work U.

In order that the cutter may act to the best advantage in cutting screw-threads, its axis ought to be placed obliquely, so that the threads on its periphery, at the point of contact, are in straight line with the threads on the work to be cut, while the direction of its up and down motion should be also in the same line.

An examination of Fig. 9 will make this clearly understood, P being the cutter, and U the work. As has been already set forth, this oblique position of the parts carrying the cutter can be given by turning the support J and fastening it in the desired position with the screws jj .

The transmission of the rotating motion of the lathe-spindle to the cutter is accomplished by means of the cog-wheels E, F, T, S, R, Q, M, N, and O.

The apparatus has thus been fully explained for external screws or other forms. For internal work the position and action of several of the parts will be different, as shown in Fig. 5, which represents the apparatus in position for internal work.

It has already been described that at that point where the cutter and the work come in contact the motion of both has to be in opposite direction to each other. This will be the case in external screw-cutting, when both rotate in the same direction, as shown in Figs. 10 and 11 and for internal screw, when both turn in opposite direction, as shown in Figs. 12 and 13, P being the cutter, and U the work, the arrows showing the direction of motion.

As the cutter has for internal work to turn in opposite direction, it is fastened to the shaft of wheel N, and wheel O and its shaft may be removed if they are in the way of the work.

The cutter and the work are moved in opposite directions, the latter being fastened to the lathe-spindle for internal screws, but in the same direction for external screws. The shafts of the wheels N O are so arranged as to receive a cutter on either of them, said cutter being attached to the first for internal, and to the second for external, work.

The arm K is then fastened to the support J by means of the key g , which moves in a slot of support J, and is pressed into a recess, 8, of arm K, by two screws, 10 10. The fastening-screw V is now loosened, and the screw-spindle W allowed to have some

play in the line of its axis by screwing back the screw 11, which is one of its bearings. The play thus given must be as much as to allow to the frame L sufficient motion on the studs l' , as the cutter requires to cut the full depth of the thread.

The motion of the frame L on the studs l' is given by the screw-spindle X in the same manner as for external work.

The different diameters of the work are also regulated by the screw-spindle W, the same as before.

To get the cutter out of the internal part of the work it is necessary that the frame L can be moved toward the right-hand side. For this purpose the arm K has so much play between the bearings of support J that it can be moved sufficiently toward the right, whereby also the wheels S and T will get out of gear and the apparatus out of motion.

A spring-catch, Z, holds the arm K and frame L in their position toward the left while the cutter is acting.

This apparatus may be also applied for cutting other regular or irregular forms, besides screw-threads, the work receiving always a shape which is an exact counterpart of the acting-surface of the cutter. Two or more ~~more~~ screws of different pitch, besides any complicated form, can be cut at the same time.

In Fig. 8, for instance, U represents a fusee for large shells, having two screw-threads of different size and pitch, both of which, as well as the entire head, are cut at one operation, the cutter P being of corresponding shape, and made in this case of several parts.

To give to the cutter the exact shape required I use generally an exact copy of the work, and by cutting into it the teeth make a cutter out of it, which is then hardened. This cutter is then fastened to the lathe-spindle in place of the work, while the unhardened cutter which is to be made is fastened on the cutter-spindle. By bringing, now, both cutters in contact the soft cutter will become an exact copy of the form required.

In this simple manner the cutters can be cheaply and quickly made or repaired.

The advantages of this invention are manifold, of which I may mention the following: First, quick and cheap productions of screw-threads and other forms; second, great exactness of the work; third, little wear of the cutting-tools.

When only external or only internal screws, or only such of a given diameter, are to be manufactured, the apparatus can be much simplified, as many parts may be dispensed with. When only fine screw-threads or smooth work are to be made it is not necessary for the apparatus to be set into an oblique position, and the universal-jointed clutch-wheels S and T may be dispensed with, and the shafts G and r' be made in one piece. The cutter may also be fastened to the lathe-spindle C, and work on the movable cutter-shaft.

The apparatus may also be applied for cutting screw-bolts with hexagonal heads simultaneously with the thread and other parts. This is illustrated in Figs. 6 and 7, where the cutter is shown to be not of circular shape, but composed of six arc-shaped sides, forming the hexagonal shape of the head while revolving, in the manner described and shown.

In the same manner the eccentrics of sewing-machines and the rotating hook of the Wheeler and Wilson sewing-machine may be cut.

Having thus described my invention, I claim as new and desire to secure by Letters Patent—

1. The screw-cutting attachment, consisting of the bed-plate I, main support J, adjustable arm K, movable cutter-carrying frame L, the arm K and frame L being adjusted to the work by a toothed segment, 5, and screw-spindle W, and by universally-jointed crank screw-spindle X, substantially as specified.

2. The combination of supplementary revolving shaft G of lathe, connected by a universally-jointed clutch-wheel mechanism ST, with shaft

r' and the cutter-shaft-revolving gear-wheels, substantially as and for the purpose described.

3. The combination of toothed and slotted segment 5 of frame L with screw-spindle W and clamp-screw V, to adjust and lock cutter-carrying frame L, substantially as set forth.

4. The combination of pendent frame L, pivoted arm K, and fixed support J with universally-jointed screw-spindle X, turning in supports of frame L, and support J, to raise or lower arm K and frame L, to work as described.

5. The combination of arm K, having recess 8 at rear part, with locking-key *g* and fastening-screws 10 of support J, to support movable frame for internal work, as described.

6. The combination of arm K with spring-catch Z of support J, to hold arm K and frame L in position against lateral displacement, substantially as set forth.

LOUIS BOLLMANN.

Witnesses:

LUOWYITNZ LONURTTING,
FZ. GUAPILL.